

# chéri

design by Tosca Design

scheda di montaggio  
assembly instructions

6477

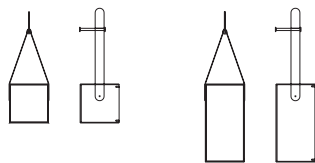

1 di 2

100% Made in Italy

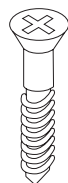

(A) x 3

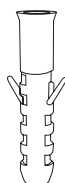

(B) x 3

ferramenta  
hardware

Fissare la staffa al muro e incastrare la vetrinetta.  
Fix the bracket to the wall and fit the showcase.

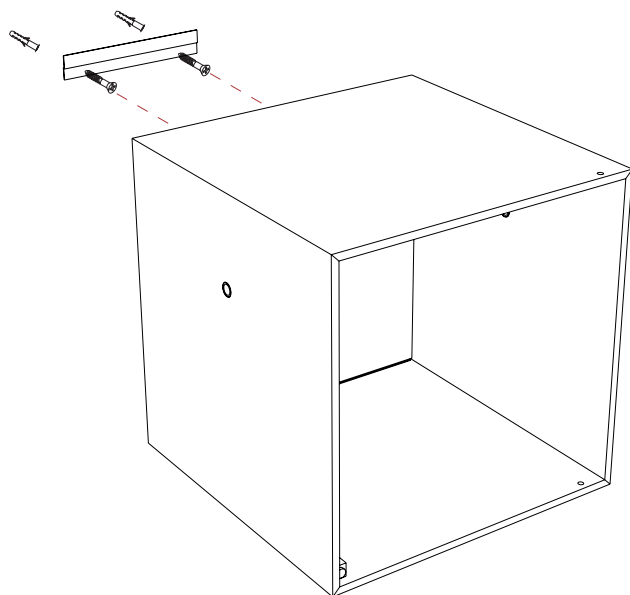

1

Fissare la fibbia ai lati della vetrina avvitando i perni dorati includendo vetro e cuoio.  
ATTENZIONE: non fissarli del tutto ma lasciarli lievemente laschi.  
Fix the buckle to the sides of the showcase by screwing the gold pins including glass and thick leather. ATTENTION: do not fasten them completely but leave them slightly loose.

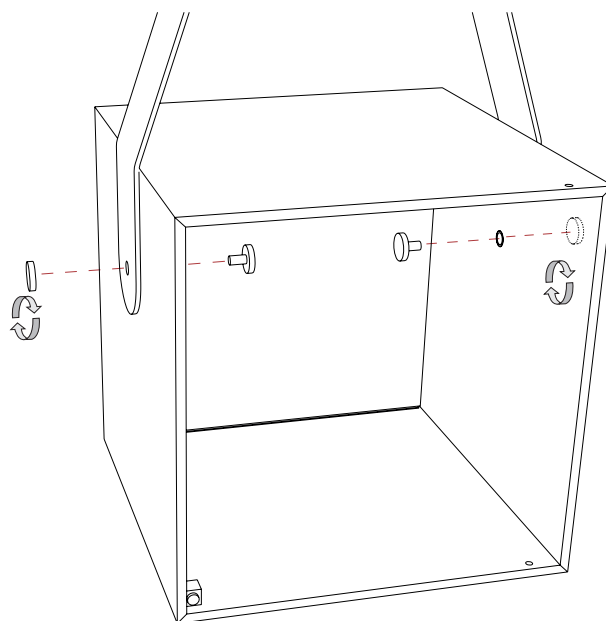

2

**Tonin**  
CASA

Tonin Casa  
divisione della  
Progetto Design International srl

Via Palladio, 43  
35010 San Giorgio in Bosco (PD), Italy

t +39 049 9453300  
f +39 049 9450725

info@tonincasa.it  
www.tonincasa.it

# chéri

design by Tosca Design

scheda di montaggio  
assembly instructions

6477

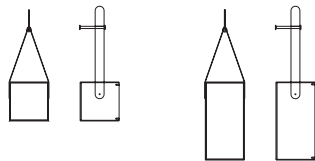

2 di 2

100% Made in Italy

Tenere la fibbia in tensione e prendere la misura tra l'inizio del vetro e l'incrocio del cuoio;  
segnare il punto di fissaggio sul muro.  
Hold the buckle in tension and take the measurement between the beginning of the glass and  
the crossing of the thick leather; mark the fixing point on the wall.

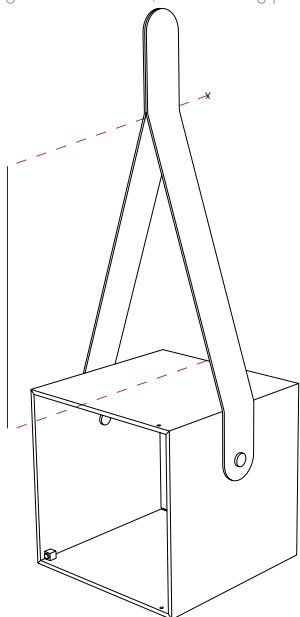

3

Fissare al muro la parte finale del perno superiore, per poi avvitare la parte più lunga dello  
stesso perno tra l'incrocio della fibbia in cuoio.  
Fix the final part of the upper pin to the wall, then screw the longer part of the same pin  
between the intersection of the thick leather buckle.

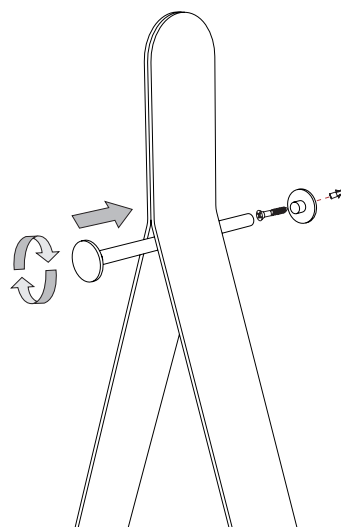

4

Mettere la fibbia dritta e fissare i perni laterali lasciati precedentemente allentati.  
Put the buckle straight and fix the lateral pins left slightly loose previously.

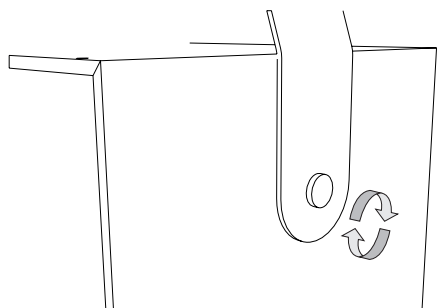

5

Montare l'anta inserendo e fissando i perni superiore e inferiore.  
Assemble the door inserting and fixing the upper and lower pins.

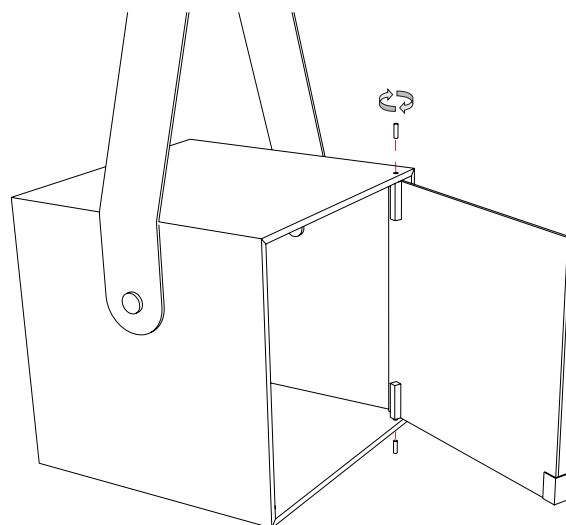

6

**Tonin**  
CASA

Tonin Casa  
divisione della  
Progetto Design International srl

Via Palladio, 43  
35010 San Giorgio in Bosco (PD), Italy

t +39 049 9453300  
f +39 049 9450725

info@tonincasa.it  
www.tonincasa.it